

# GL 1200



## SPECIFICATIONS

item:	GL 1200
body:	aluminium, powder coated
available colours:	silver-grey
weight:	12.3 kg
on / off switch:	on the rear side of the device
environmental conditions:	for indoor use only
cooling:	active ventilation
light source:	PHILIPS 1,200 W MSD metal halide lamp
socket:	G22
recommended projections distance in normal room light:	15 m
recommended projection distance in darkness:	60 m
average lifetime of the lamp:	3,000 hours
colour temperature:	6,500° Kelvin
luminous flux of the lamp:	92,000 Lumen
gobo size / image size:	105 mm ø / 68 mm ø
output power:	1,200 W
input voltage:	180-240 V AC / 50-60 Hz
active power (power consumption):	1,350 W
efficiency:	0.65 cos. φ
electrical protection:	protection class I
standard lens:	150 mm
connectors for lighting effects:	2 x 12 V AC
item number:	20000230 (silver-grey)

## COMPONENTS

Standard series including 1,200 W metal halide lamp, standard lens 150 mm, power cable with plug. The machine is ready to plug in and run. Required accessories: glass gobo with individually designed motif, mounting plate for floor, wall or ceiling mount.

## MEASUREMENTS

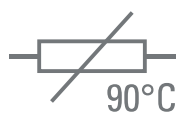
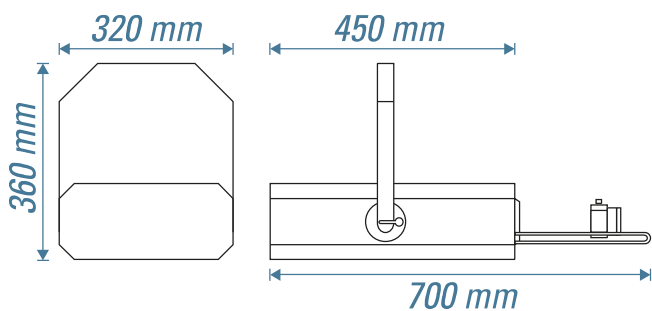

derksen®  
benelux lichttechniek

Derksen Benelux Lichttechniek  
Vlinderhof 3  
5345 JX Oss  
Nederland

tel: +31 (0) 412 69 08 70  
fax: +31 (0) 412 69 08 69

info@derksenbenelux.nl  
www.derksenbenelux.nl